



# Referee Handout

## WEATHER CONDITIONS

- Games will be played in all weather conditions except lightening, hail or other dangerous conditions.
  - Follow the Lightning and Inclement Weather Policy that is posted on the Canfield Soccer Club (CSC) Web Site
- Once the official arrives at the field, they are in charge, not the coaches, in determining whether or not to call a match due to weather conditions.
  - If in doubt contact CSC Assignor Jeff Joseph at (330) 727-6350 or CSC Vice President Brian Governor at (330) 720-4141 for a ruling.

## ARRIVAL FOR SOCCER MATCH

- The referees assigned to that game should arrive **15 minutes prior** to the start of the soccer match.
  - Games will be every night of the week at the Township park, starting promptly at 6:00 pm and then again at 7:15 pm.
- You should be in your full uniform, including your 2011 referee patch.
- When you get to the field if your field does not have corner flags, please go to the grey box located at the fields and get flags.
- There will be first aid kits and other items that might be needed inside the box. Please check them out and be familiar with what is inside,
- All players and coaches should report to the assigned field **15 minutes prior** to the assigned time.
- Check all players' shoes and shine guards, so that all game will start on time.

## CANCELLATION / INTERRUPTION OF SOCCER MATCH

- Coaches can not cancel games for any reason with out prior approval of the Vice President.
- If the game is interrupted, **seek safe shelter but do not leave until** confirmation that play will not resume is received from the referee.
- If the game is stopped before the end of the first half, it will be restarted from the beginning at another time.

- If the game is stopped after the half-time, it will consider a complete game.
- Referee need to notify and communicate with BOTH coaches during rain cancellation if at field when inclement weather begins which causes a match to be delayed or cancelled.

### **RESCHEDULING GAMES**

- All games should be played at the assigned times on the assigned fields.
- If a game is canceled the assignor must be notified by the official in charge, and it must be rescheduled by the assignor to ensure that referee's are present.

## **RULES**

All official FIFA laws will apply with the following exceptions:

### **ALL AGE GROUPS:**

- All players will play at least half of every game.
- Players are permitted to score a maximum of three goals. Once a player has scored three goals, they must be moved to a defensive position and any more scored by that player will not be counted.
- Handballs that are deliberate will be called.
  - FIFA rules define a handball as intentional contact below the shoulder to gain an advantage.
    - Contact below the shoulder alone is not a foul and will not be called.
    - *Intent is the judgment of the official.*
- If your opponent shows up with fewer players, please play short sided.
- The assumptions are that good sportsmanship will prevail.
- **No slide tackling is permitted.**
- Any shoes with a spike on the toe are **not permitted.**
  - Removing the front spike from the molded football spike is acceptable.

- Substitution Rules:
  - The proper protocol to address the official when requesting a substitutions:
    - "Sub-Sir", Sub-Ma'am", or 'Sub-Please",
    - **NOT** "Hey Ref" or "I want to sub."
  - Players must present themselves at the mid line for substitution before a stoppage in play occurs.
    - This allows the referee to see that there are players waiting to enter the game to help speed the game along.
  - All players must come completely off the field before the substitution players come onto the field.
  - When can a team substitute:
    - During a throw in when **your** team controls the ball.
    - Prior to a goal kick by either team
    - After a goal by either team.
    - After an injury when play has stopped by the referee
      - Substitution for the injured player only.
      - Goalies are **not required** to leave if play has stopped for an injury to the goalie. ***The discretion is up to the coach whether or not to substitute for an injured goalie.***
  - No substitution during the last two minutes of the half or the game.
  - No substitution on a corner kicks.

Please remember that you are there to help these kids (parents and coaches) learn the game of soccer. **You are in charge of the field.** You have the right to stop any game for an abusive parent, ask the Coaches to please advise their parent that the game will be stopped if the abuse continues.

**If you have any situation, please call me as soon as possible, so that I am aware of what went on (330-727-6350).**

#### TIME SHEETS:

- Make sure that your name, phone number, complete address are on these sheets.
- Make sure to **KEEP A COPY OF ALL TIME SHEETS.**
- Fill in the date, make sure that at least one coach signs you sheet **or you will not get paid for that game.** This is your verification that you were there and worked.
- Time sheets can **only** be submitted to the assignor via email, fax, or regular mail at the below contact information.
- CSC will pay for all games that you worked **one week after the conclusion of the season** provided your game log has been submitted by August 5, 2011.
  - The pay rate is \$15.00 per game officiated and signed off by a coach.
  - **Delays in submission will result in delays in payment.**
  - The check will be mailed to the address listed on the OYSAN official roster.

#### EQUIPMENT:

- Be on time (15 minutes before the match is to start).
- Be dressed as the referee.
- Have a stop watch.
- Have a coin for the coin toss.
- Have your time sheet and a pen to write with.

Canfield Soccer Club  
Jeffrey A. Joseph , *Assignor*  
P.O. Box 761  
Canfield, Ohio 44406

Email: jajoseph.jj@gmail.com  
Cell Phone: 330-727-6350  
Fax: 1-866-936-5328

# LIGHTNING AND INCLEMENT WEATHER POLICY

## WEATHER

### *Recognition:*

Coaches, athletic trainers, athletes, administrators and contest officials should be educated regarding the signs indicating thunderstorm development. Since the average distance between successive lightening flashes is approximately two to three miles ANYTIME that lightning can be seen or heard, the risk is already present. Weather can be monitored using the following methods:

- **Monitor Weather Patterns** – Be aware of potential thunderstorms by monitoring local weather forecasts the day before and morning of the competition, and by scanning the sky for signs of potential thunderstorm activity.
- **National Weather Service** – Weather can also be monitored using small, portable weather radios from the NWS. The NWS uses a system of severe storm watches and warnings watch indicates conditions are favorable for severe weather to develop in an area; a warning indicates severe weather has been reported in an area, and everyone should take proper precautions. Any thunderstorm poses a risk of injury or death even if it does not meet the criteria for severe weather. Therefore, anytime thunderstorms are in the forecast (even if it is only a 20 percent chance), event organizers should be at a heightened level of awareness to the potential danger of lightning.

### *Management:*

- **Evacuation** – If lightening is imminent or a thunderstorm is approaching, all personnel, athletes and spectators shall evacuate to available safe structures or shelters.
- **Thirty-minute rule** – Competition or practice shall be suspended once lightning has been recognized or thunder is heard. It is required to wait at least 30 minutes after the last flash of lightning is witnessed or thunder is heard prior to resuming practice or competition. Given the average rates of thunderstorm travel, the storm should move 10-12 miles away from the area. This significantly reduces the risk of local lightning flashes. Any subsequent lightning or thunder after the beginning of the 30 minute count shall reset the clock, and another count shall begin. If after two 30 minute waiting periods have been concluded and a third 30 minute period needs to be initiated, all competition or practice shall be cancelled for the day. This is the three strikes and out rule.

## Canfield Soccer Club Goal Safety Policy 2012 Season

It is the intention of the Board of Trustees of the Canfield Soccer Club that **goal safety** be a priority. Therefore, the following policy is adopted. The Canfield Soccer Club requires the following prior to all practices and games:

- 1) Coaches or other responsible person will make a physical inspection of each **goal** prior to the game/activity to assure that goals are securely anchored per the attached guidelines.
- 2) The coaches for the last game of the day will make sure the goals are secured according to the attached guidelines.
- 3) That all parents and guardians of Canfield Soccer Club participants are told of the dangers of unsecured goals and the parents' responsibility to keep kids away from goals, and to secure goals if necessary.
- 4) Canfield Board Members will conduct random site surveys.

To reach this end, all coaches will receive a copy of this policy and will be instructed to inspect goals used during their practices and games.

Coaches will remind their players, and discuss with the children's parents or guardians, the necessity of not playing on, climbing on, or moving the goals. It is deemed appropriate that players violating this rule may, at the coaches' discretion, sit out a half a game or entire game. Players consistently violating the rule can be subject to a disciplinary hearing of the Board.

Parents and guardians will be given written notification that they are responsible to keep their children away from all soccer goals when the children are not participating in Canfield Soccer Club sponsored practices and games. This includes siblings and friends of soccer players.

For non-club/league owned fields and/or goals, the owners of the fields and/or goals will be reminded of **safety** requirements. This is in addition to the checking of goals as listed above.

The President will have random site surveys done to certify compliance with this policy. The President of the Board will certify to OYSAN no later than June 1 of each year that a policy is in place and enforced.

**Canfield Soccer Club Goal Safety Policy**  
**2012 Season**

**Guidelines for checking goals**

- Each goal should have at least two stakes or anchors securing both ground bars to the ground. One stake on each ground bar shall be at the rear of the ground bar.
- At the rear of the goal, nets shall be secured to the ground with at least two stakes driven flush with the ground.
- Nets shall be secured to posts, crossbars, and backdrops with tape or Velcro straps at intervals of no less than one every four feet.
- Warning labels will be attached to each goal.
- Hammers or sledges, stakes, tape or Velcro, and warning labels will be located at all fields in equipment storage boxes and are to be used as needed.
- The stakes should be driven into the ground fully.

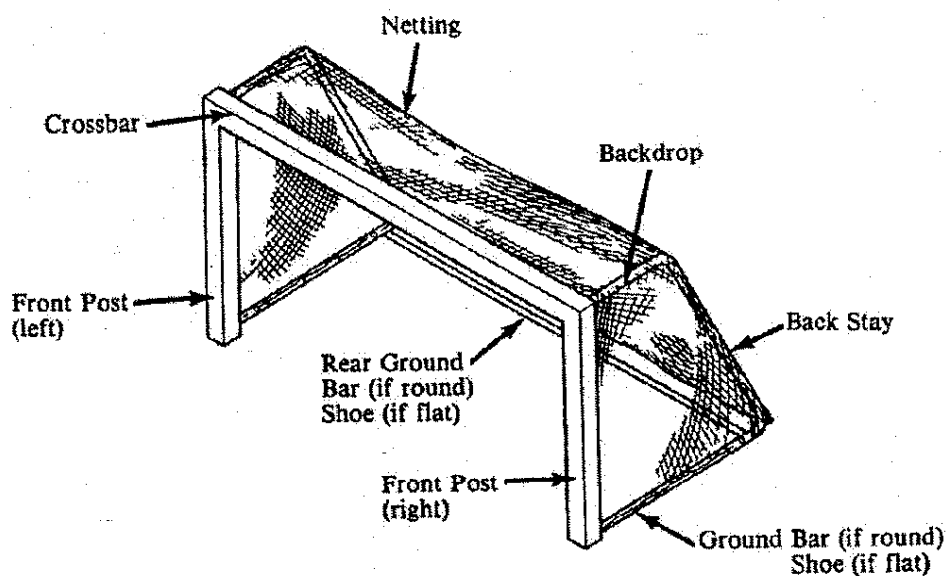

**Figure 1: Components of a Movable Soccer Goal**

**Canfield Soccer Club Goal Safety Policy**  
**2012 Season**

Dear parents and guardians of soccer players:

One of the primary objectives of the Canfield Soccer Club is to insure that your children have a safe environment to play in. A large part of doing so is to make sure our goals remain securely anchored to the ground and nets are firmly attached to the goals.

In an effort to keep the goals and nets such, we require you to prohibit your children from using our goals when not participating in Club sponsored soccer activities, practices, or games. This especially applies to children climbing on or hanging from nets or goal frames. These activities can result in serious injury, and unfortunately death according to the Consumer Product Safety Commission and Ohio Youth Soccer Association North. The only exceptions to this policy will be if your child is participating with a school or another Ohio Youth Soccer Association North sanctioned team.

We ask if you observe any children who are not part of Canfield Soccer Club, a school, or another Ohio Youth Soccer Association North sanctioned team conducting these activities, that you politely ask the child or children to stop. If the activity continues please notify any coach, Canfield Soccer Club officer, or referee as soon as possible. Canfield Soccer Club is required to strictly enforce this policy and exceptions will not be permitted.

Finally, if you see soccer goals or nets that are not secure please notify a coach or Canfield Soccer Club officer.

Soccer is a fun and enjoyable activity for our children, families, and the Canfield community. We want to make sure this enjoyment is never marred by a preventable accident.

Brian Governor  
President  
Canfield Soccer Club