

Canfield Soccer Club Goal Safety Policy 2011 Season

It is the intention of the Board of Trustees of the Canfield Soccer Club that **goal safety** be a priority. Therefore, the following policy is adopted. The Canfield Soccer Club requires the following prior to all practices and games:

- 1) Coaches or other responsible person will make a physical inspection of each **goal** prior to the game/activity to assure that goals are securely anchored per the attached guidelines.
- 2) The coaches for the last game of the day will make sure the goals are secured according to the attached guidelines.
- 3) That all parents and guardians of Canfield Soccer Club participants are told of the dangers of unsecured goals and the parents' responsibility to keep kids away from goals, and to secure goals if necessary.
- 4) Canfield Board Members will conduct random site surveys.

To reach this end, all coaches will receive a copy of this policy and will be instructed to inspect goals used during their practices and games.

Coaches will remind their players, and discuss with the children's parents or guardians, the necessity of not playing on, climbing on, or moving the goals. It is deemed appropriate that players violating this rule may, at the coaches' discretion, sit out a half a game or entire game. Players consistently violating the rule can be subject to a disciplinary hearing of the Board.

Parents and guardians will be given written notification that they are responsible to keep their children away from all soccer goals when the children are not participating in Canfield Soccer Club sponsored practices and games. This includes siblings and friends of soccer players.

For non-club/league owned fields and/or goals, the owners of the fields and/or goals will be reminded of **safety** requirements. This is in addition to the checking of goals as listed above.

The President will have random site surveys done to certify compliance with this policy. The President of the Board will certify to OYSAN no later than June 1 of each year that a policy is in place and enforced.

Canfield Soccer Club Goal Safety Policy
2011 Season

Guidelines for checking goals

- Each goal should have at least two stakes or anchors securing both ground bars to the ground. One stake on each ground bar shall be at the rear of the ground bar.
- At the rear of the goal, nets shall be secured to the ground with at least two stakes driven flush with the ground.
- Nets shall be secured to posts, crossbars, and backdrops with tape or Velcro straps at intervals of no less than one every four feet.
- Warning labels will be attached to each goal.
- Hammers or sledges, stakes, tape or Velcro, and warning labels will be located at all fields in equipment storage boxes and are to be used as needed.
- The stakes should be driven into the ground fully.

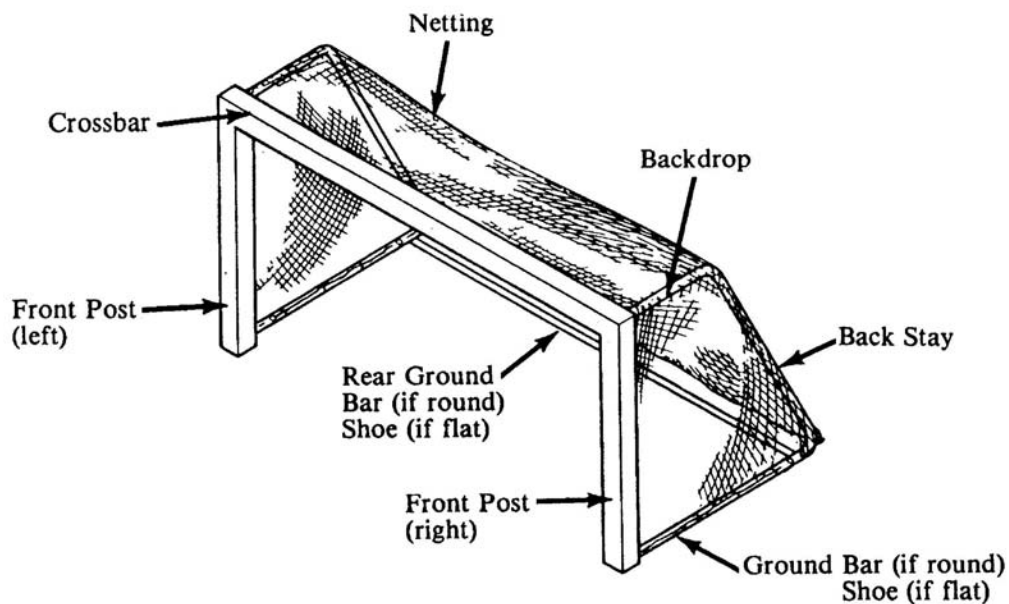

Figure 1: Components of a Movable Soccer Goal

Canfield Soccer Club Goal Safety Policy
2011 Season

Dear parents and guardians of soccer players:

One of the primary objectives of the Canfield Soccer Club is to insure that your children have a safe environment to play in. A large part of doing so is to make sure our goals remain securely anchored to the ground and nets are firmly attached to the goals.

In an effort to keep the goals and nets such, we require you to prohibit your children from using our goals when not participating in Club sponsored soccer activities, practices, or games. This especially applies to children climbing on or hanging from nets or goal frames. These activities can result in serious injury, and unfortunately death according to the Consumer Product Safety Commission and Ohio Youth Soccer Association North. The only exceptions to this policy will be if your child is participating with a school or another Ohio Youth Soccer Association North sanctioned team.

We ask if you observe any children who are not part of Canfield Soccer Club, a school, or another Ohio Youth Soccer Association North sanctioned team conducting these activities, that you politely ask the child or children to stop. If the activity continues please notify any coach, Canfield Soccer Club officer, or referee as soon as possible. Canfield Soccer Club is required to strictly enforce this policy and exceptions will not be permitted.

Finally, if you see soccer goals or nets that are not secure please notify a coach or Canfield Soccer Club officer.

Soccer is a fun and enjoyable activity for our children, families, and the Canfield community. We want to make sure this enjoyment is never marred by a preventable accident.



Jeffrey A. Joseph
President
Canfield Soccer Club